

SUPERCRANE™ 285

- 4/2 Fall hook block
- Remote Control (Optional)

- Max. Working Radius (Main Boom) 26.9'
- Max. Lifting Capacity 6,210lb

- Rubber tracks
- Load moment Indicator system



The Preston Rentals SuperCrane™ 285 punches way above its weight with a massive 6,210lb lifting capacity. Its slim body is able to fit through most doorways allowing access to areas previously inaccessible to standard cranes. The 285 has proven to be one of the most popular models of mini cranes and can be used in a wide variety of applications. Consider the possibilities...



COUNT ON US

Phone 888 399 3325 | prestonrentals.com

SPECIFICATIONS SUPERCRAANE™

285

SPECIFICATIONS

Model	
Maximum Capacities	Main Boom : 4 Part Line - 6,210 lb. (2820kg) 2 Part Line - 3,100 lb. (1405kg) 1 Part Line - 1,560 lb. (708kg) Boom Tip Searcher Hook : 1,870lb. (850kg) Auxiliary Winch : 1,980 lb. (900kg)
Maximum Lifting Height	Hook Block, Ball : 28.54' (8.7m) Boom Tip Searcher Hook : 31.8' (9.7m)
Maximum Radius	Main Boom : 26.9' (8.2m) Boom Tip Searcher Hook : 29.4' (8.9m) Auxiliary Winch : 27.6' (8.4m)
Maximum Reach Below Grade	4 Part Line : - 33' (10.1m) 2 Part Line : - 66' (20.2m) 1 Part Line : - 132' (40.4m) [164' (50m)w/ optional wire rope] Auxiliary Winch 1 Part Line : 328'(100m)
Boom System	Auto Telescopic 8.3' - 28.1' (2.53m - 8.57m) Range 0°- 76°
Travel System	0 - 1.37 mph 20°Gradability Track Footprint : 3'2" x 8" (975mm x 200mm) ea. Ground Pressure : 7.3psi, (50.0kpa), average/varies
Engine	Diesel : Perkins, E672L-F6701, 8.57hp, EPA Tier 4 Final, 3.1 gal. tank
Dual Power (Diesel / Electric)	Electric : Motor 5.5kw 208-230V 3P, Inverter Controlled 60Hz
Remote Control (wireless)	Graduated Crane & Outrigger Operation, 4 Micro Speed Settings, Digital Load & Capacity Display
Net Weight	Diesel : 4,390 lb. Diesel / Electric : 4,765 lb.
Optional Equipment	Boom Tip Searcher Hook, White Rubber Tracks, Single Part Ball / Hook, Man Basket, Rotation Resistant Wire Rope, Oktopus Glass Lifter / Manipulator, Custom Paint Color, Exhaust Scrubber, Transport Trailer, Outrigger Pads

WORKING RANGE

Working Range Chart (4Part)

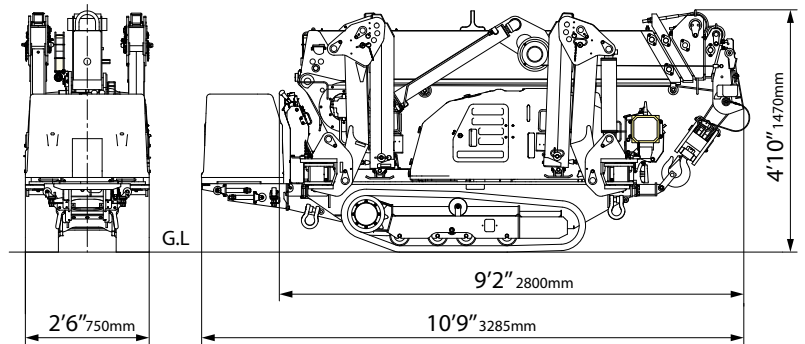
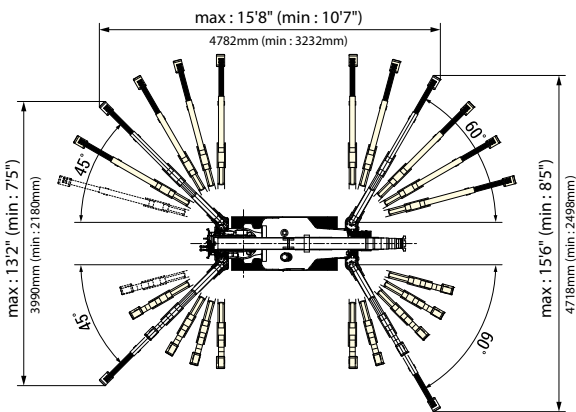
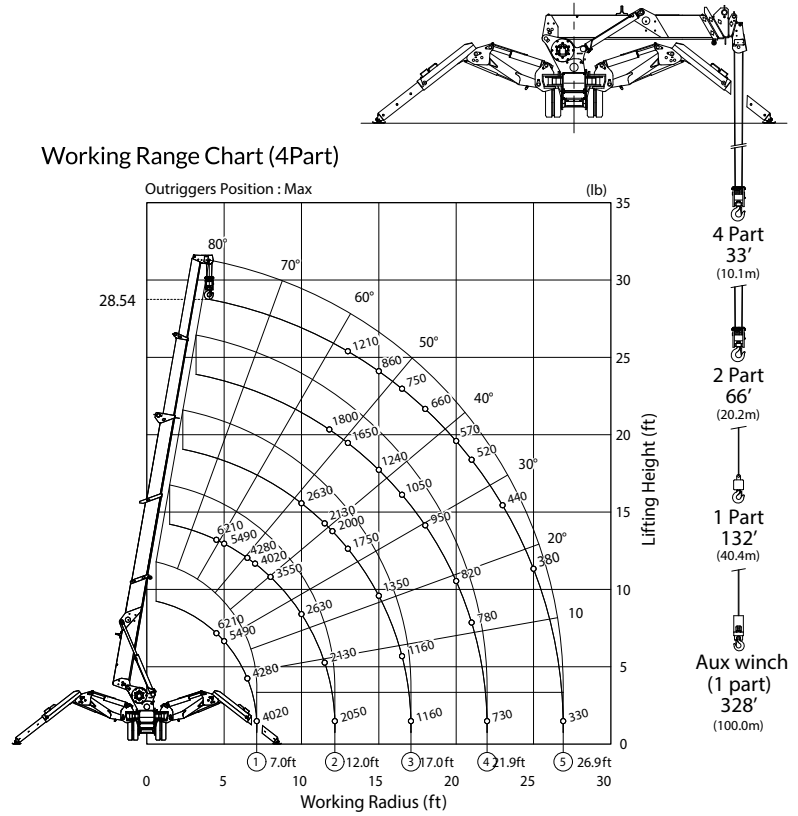

SPECIFICATIONS SUPERCRAANE™

285

LOAD CHART

MAXIMUM Outriggers, 4 PART LINE					
Boom Length	8.3 Ft.	8.4 - 13.3 Ft.	13.4 - 18.2 Ft.	18.3 - 23.2 Ft.	23.3 - 28.1 Ft.
Radius (Ft.)	Load (Lbs.)	Load (Lbs.)	Load (Lbs.)	Load (Lbs.)	Load (Lbs.)
4.5	6210	6210	2630		
5.0	5490	5490	2630		
6.5	4280	4280	2630	1800	
7.0	4020	4020	2630	1800	1210
8.0		3550	2630	1800	1210
10.0		2630	2630	1800	1210
11.5		2130	2130	1800	1210
11.8		2080	2050	1800	1210
12.0		2050	2000	1780	1210
13.0			1750	1650	1210
15.0			1350	1240	860
16.5			1160	1050	750
17.0			1160	1010	710
18.0				950	660
20.0				820	570
21.0				780	520
21.9				730	480
23.0					440
25.0					380
26.9					330

OTHER THAN MAXIMUM Outriggers, 4 PART LINE					
Boom Length	8.3 Ft.	8.4 - 13.3 Ft.	13.4 - 18.2 Ft.	18.3 - 23.2 Ft.	23.3 - 28.1 Ft.
Radius (Ft.)	Load (Lbs.)	Load (Lbs.)	Load (Lbs.)	Load (Lbs.)	Load (Lbs.)
4.5	3790	3790	1100		
5.0	3720	3720	1100		
6.5	2410	2410	1100	880	
7.0	2100	2100	1100	880	720
8.0		1500	1100	880	720
10.0		1110	1100	880	720
11.5		850	900	880	720
11.8		810	870	880	720
12.0		790	850	860	720
13.0			750	750	720
15.0			590	600	600
16.5			440	500	500
17.0			440	450	450
18.0				400	400
20.0				340	340
21.0				300	300
21.9				260	260
23.0					220
25.0					170
26.9					130

Disclaimer : All information provided in this publication is correct at time of printing. Please contact Preston Rentals for any updated versions.

YOU CAN COUNT ON PRESTON RENTALS FOR YOUR SPECIALIZED CONSTRUCTION NEEDS

Preston Rentals meets the needs of leading building and construction companies by providing equipment throughout the entire North American continent.

For more information, rates or technical specifications on our products please call us today on 888 399 DECK (3325) or visit our website at www.prestonrentals.com



Specialized Equipment Rental **Solutions**

Preston Rentals (NV) LLC

5168 W. Eldorado Lane
Las Vegas, NV 89139
sales@prestonrentals.com

Preston Rentals (TX) LLC

3517 2nd Avenue S.
Texas City, TX 77590
sales@prestonrentals.com

Preston Rentals (CA) LLC

135 South State College Blvd
Suite 200, Brea, CA, 92821
sales@prestonrentals.com

Preston Rentals (TN)

3200 West End,
Nashville, TN 37203
sales@prestonrentals.com

Preston Rentals (CO)

1900 W Hamilton Place
Sheridan, CO 80110
sales@prestonrentals.com



COUNT ON US

Phone 888 399 DECK | prestonrentals.com